



Superpositions and Entanglement

{Preface - *In this, the last chapter in the ‘How Small Is It’ video book, we’ll cover quantum superposition and quantum entanglement. We’ll also finish the work on the double slit experiment we covered in our first chapter on ‘The Microscopic’. We’ll be using electron spin and polarized light in most of our examples. Beginning with light, we’ll cover exactly how polarization works. Then we’ll use it to illustrate how we know which slit light went through in the double slit experiment. This illustration will highlight the nature of quantum linear superposition. As part of this we’ll take a look at Schrodinger’s Cat.*

With superposition in hand, we’ll cover how these superposition states can become entangled across multiple particles. We’ll start with some classical behavior associated with water waves and spinning coins. Then, using electron spin, we’ll illustrate entanglement. We’ll follow that with Einstein’s problem with ‘spooky action at a distance’. We’ll cover several experiments both thought (from John Bell) and real as quantum physics progressed in its ability to manage the quantum world. We’ll see what a ‘ghost image’ is and how it was used to show Einstein was wrong. As part of this segment, we’ll cover the ‘Quantum Eraser’ experiment.

We’ll end with a look at Quantum Computers. Here we cover how electrons are controlled in such a way that they can be put into and taken out of a superposition state at will. And in addition, they can be managed into and out of entangled states. This ability enables quantum computing.}

Introduction

[**Music:** Bach - Flute Concerto in B Flat, Adagio]

Quantum state superpositions and entanglement are two of the most fundamental concepts in quantum mechanics, and also two of its most misunderstood. And they are turning out to be the key to the next generation of quantum computing.

In our first chapter, The Microscopic, we covered the double slit experiment that showed how photons and electrons display both wave and particle properties. It’s called wave-particle duality or complementarity. The key to the experiment was to observe what happens when we detect the slit a particle went through. For photons, we never explained how we could detect a photon without disturbing its path. This final chapter brings us full circle where we will cover in detail how this was done.

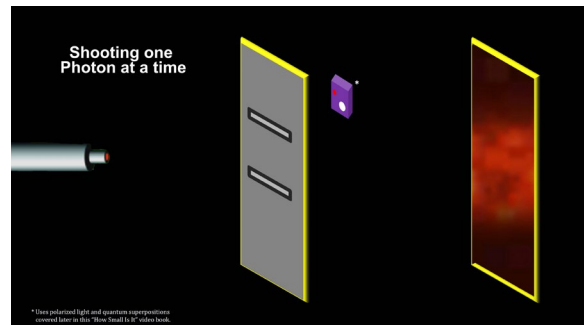



In our second chapter on The Atom, we covered Schrodinger’s equation with its probability wave; Heisenberg’s Uncertainty Principle; and Pauli’s Exclusion Principle with electron spin; These constitute the base physics for understanding superpositions and entanglement.

Schrodinger Equation

$i\hbar \frac{\partial \Psi(x,t)}{\partial t} = (-\hbar^2/2m) (\nabla^2 \Psi(x,t)) + U \Psi(x,t)$

Where:
 Ψ = the wave as a function of x and t
 t = time
 \hbar = Planck's constant / 2π
 $i = (-1)^{1/2}$
 m = mass of the particle
 U = potential energy at x and t

Where:
 $\lambda = h/p$ $p = mv$ $\lambda = h/mv$
 λ = wavelength
 p = momentum
 h = Planck's constant

Heisenberg Uncertainty Principle

Let
 x = the position
 p = the momentum
 Δx = the uncertainty in position
 Δp = the uncertainty in momentum
 \hbar = Planck's constant / 2π

Then
 $\Delta x \Delta p \geq \hbar/2 = 6.58 \times 10^{-16} \text{ eV}\cdot\text{s}$

Pauli Exclusion Principle

Electron Spin

Intrinsic value
 $s = 1/2$

Quantum number values
 $m_s = \begin{cases} +1/2 \text{ for spin up} \\ -1/2 \text{ for spin down} \end{cases}$

We’ll cover exactly what quantum superposition and entanglement are. We’ll cover Einstein’s problem with quantum mechanics and his prediction that we will someday find “hidden variables” to explain entanglement. We’ll cover a thought experiment designed to show that “hidden variables” cannot exist. It’s called Bell’s Theorem or Bell’s Inequality. We’ll cover a real experiment that uses entangled photons to create “Ghost Images” that produce a Bell Inequality. Along the way, we’ll clear up a few misconceptions about Schrodinger’s Cat and the Quantum Eraser.

Hidden Variables

Bell's Inequality

Test A $\theta = 0$ Test B θ Test C $\theta = 90$

$N(A\bar{B}) + N(B\bar{C}) \geq N(A\bar{C})$

We have
 $P(A\bar{B}) + P(B\bar{C}) \geq P(A\bar{C})$

Let
 $P(A) = 1$ $P(B) = \cos^2 \theta$ $P(\bar{B}) = \sin^2 \theta$
 $P(\bar{C}) = \cos^2 2\theta$ $P(C) = \sin^2 2\theta$

If $\theta = 45^\circ$ then
 $P(A\bar{B}) = 1 \times \sin^2 45^\circ = .25$
 $P(B\bar{C}) = \cos^2 45^\circ \times \sin^2 90^\circ = .5 \times 1 = .5$
 $P(A\bar{C}) = 1 \times \sin^2 90^\circ = 1 \times 1 = 1$

And
 $.25 + .5 \geq 1$ False

Entangled Superposition States

Entangled Superposition States
 $|\Psi\rangle = \frac{1}{\sqrt{2}} (\cos \theta |0\rangle + \sin \theta |1\rangle)$
 $\theta = \text{polarization angle}$
 $|\Psi\rangle = \text{polarization superposition state}$
 Circular Angular Momentum of quantum state
 $\langle S_z \rangle = \frac{1}{2} \cos 2\theta$ $\langle S_x \rangle = \frac{1}{2} \sin 2\theta$

Quantum Eraser Experiment

Delayed Quantum Eraser

- At t_1 , the s photon passes through double slit with which-way information.
- At t_2 , the p photon encounters polarization filter erasing the which-way information the s photon acquired at t_1 .
- At t_3 , the s photon contributes to an interference pattern showing that the which-way information was erased.**

**Incorrect - which-way info still available.
 **Incorrect - the pattern is not an interference pattern.



We'll end with a look at Quantum Computing and how it directly manifests and leverages these quantum properties. Our first encounter with quantum superpositions will be the double slit experiment. So, in preparation, we'll cover some key characteristics of light polarization.

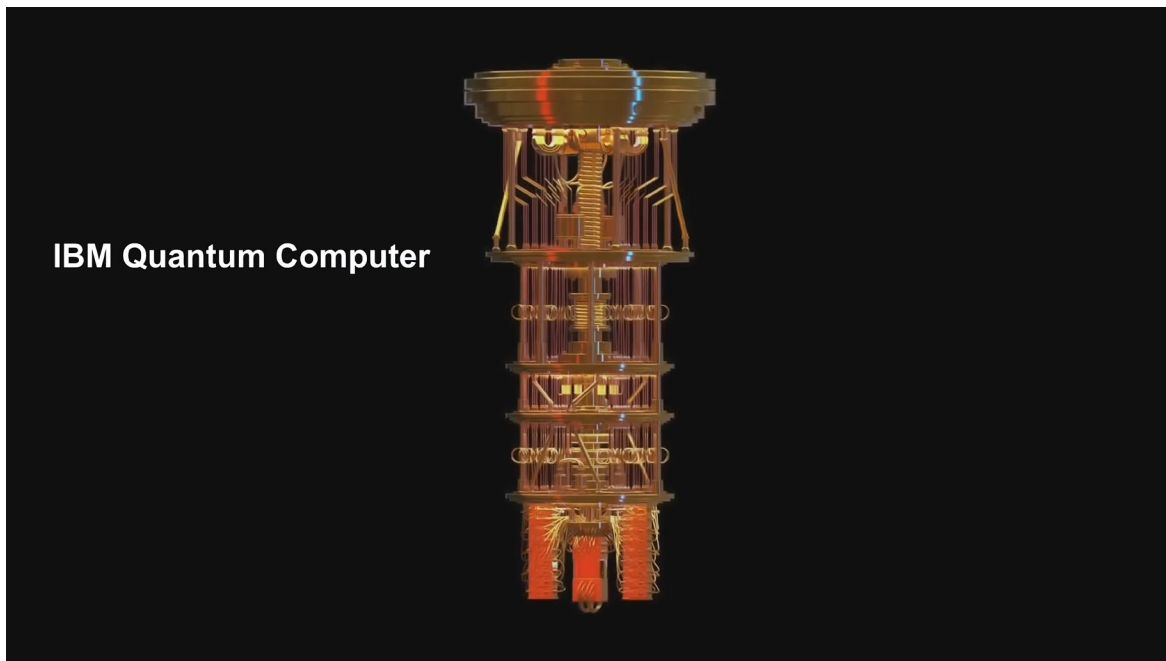

Light Polarization

We understand light as an electromagnetic wave.

The direction of the electric field is called the wave's linear polarity. Here we see the polarity at different angles from a fixed reference. It is also possible for the polarity to be rotating clockwise or counter-clockwise around the line of motion. These properties hold for the basic unit of light – the photon.

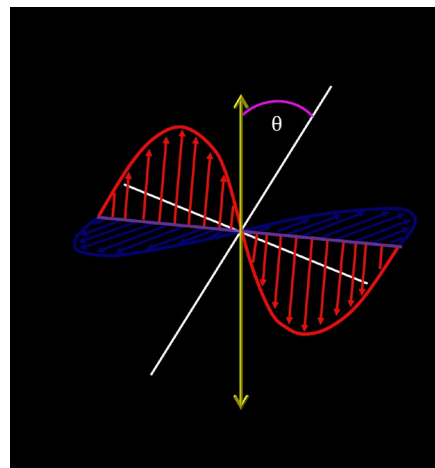



When light passes through a polarized lens, the amount of light that makes it through depends entirely on the angle between the incoming light’s polarization and the polarization direction of the lens. To see this, here are a couple of experiments you can do at home if you have three pairs of polarized glasses. Photons leaving the background table have a wide variety of polarizations. We start with a lens that only allows light polarized in the vertical direction to pass through. All the other light is blocked. We’ll call this lens A. If we bring in a second lens (lens C) and orient it the same as the first, all the light that passed through A, passes through C. But as we rotate lens C, we see the amount of light passing through is going down. By the time we reach 90 degrees, C is blocking all the light that passed through A.

Linear Polarization

Malus' Law

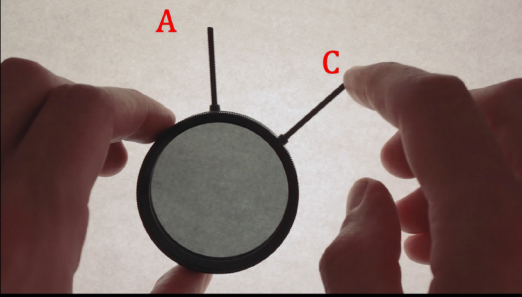

$E_{||} = E \cos\theta$ passes through the lens
 $E_{\perp} = E \sin\theta$ blocked by the lens
 $I_p = I \cos^2\theta$

Where

- E = incoming electric field strength
- $E_{||}$ = strength parallel to the vertical
- E_{\perp} = strength perpendicular to the vertical
- θ = polarization angle
- I = intensity of light flowing into the lens
- I_p = intensity of light passing through the lens
- I_f = intensity of light blocked the lens

If $\theta = 60^\circ$, $I_p = 25\%$, $I_f = 75\%$

Now, if we bring in a third lens (lens B) and place it between the first two, and angle it at 45 degrees, we see that light that could not make it through C before is now coming through. In other words, lens B designed to reduce the amount of light that reaches C, actually enables more light to get through C.

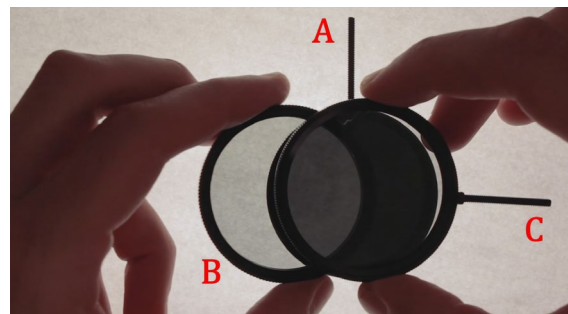

To see what is happening here, we need to go down to the photon level. Classically, we calculated the percentage of light that goes through a lens. But a photon will go through or not go through. It cannot be divided. In quantum mechanics, it’s the angle between the orientation of the photon’s quantum state and the orientation of the lens’ polarization that provides the probability for passing



through the lens. In addition, the interaction between the lens and the photon will change the orientation of the photon's state to equal the orientation of the lens it passed through.

Linear Polarization

Before

$\alpha = 0^\circ$
 $\beta = 30^\circ$
 $\theta = 30^\circ$
 $P_p = .75$

After

$\alpha = 30^\circ$

Photon Pass Probability

$P_p = \cos^2 \theta$
 $P_f = \sin^2 \theta$
 $P_p + P_f = 1$

Where

$|\alpha\rangle =$ photon quantum state
 $\alpha =$ photon angle from vertical
 $\beta =$ lens angle from vertical
 $\theta =$ angle between α and β
 $= |\alpha - \beta|$
 $P_p =$ probability of passing
 $P_f =$ probability of failing

With this understanding, we can examine how light made it through Lens C once we added lens B. Here we have a number of photons with random polarizations trying to pass through the vertically polarized lens A. Some make it and some don't. All the photons that passed through A have now been changed to have the quantum state “vertical” to match the lens. With this polarization, the probability of passing through lens C, which is rotated 90 degrees from the vertical, is zero. No light gets through C. Now we introduce lens B, which is rotated 45 degrees from vertical. We see that some of the vertically polarized photons coming through lens A will pass through lens B. In addition, the interaction between the photons and lens B changed the photons' quantum state to “oriented at 45 degrees” to match the lens. This enables some of the photons that passed through lens B to now pass through lens C.

Photons Random Polarized

$\theta = |\alpha - \beta| = \alpha$

$|0^\circ\rangle$
 $P_p = 1$

$|30^\circ\rangle$
 $P_p = .75$

$|45^\circ\rangle$
 $P_p = .5$

$|60^\circ\rangle$
 $P_p = .25$

$|90^\circ\rangle$
 $P_p = 0$

Photons Polarized Up

$\theta = |\alpha - \beta| = |0 - 45| = 45$

$|0^\circ\rangle$
 $P_p = .5$

$|0^\circ\rangle$
 $P_p = .5$

Photons Polarized at 45°

$\theta = |\alpha - \beta| = |45 - 90| = 45$

$|45^\circ\rangle$
 $P_p = .5$

$|45^\circ\rangle$
 $P_p = .5$

Photon Pass Probability

$P_p = \cos^2 \theta$
 $P_f = \sin^2 \theta$
 $P_p + P_f = 1$

Where

$|\alpha\rangle =$ photon quantum state
 $\alpha =$ photon angle from vertical
 $\beta =$ lens angle from vertical
 $\theta =$ angle between α and β
 $= |\alpha - \beta|$
 $P_p =$ probability of passing
 $P_f =$ probability of failing

A

$\beta = 0^\circ$

B

$\beta = 45^\circ$

C

$\beta = 90^\circ$



The key takeaway here is that objects like lenses, crystals, electric fields etc. can and do modify the quantum states of particles that encounter them.

Linear Superposition

Based on the wave nature of particles, superposition is the combining of multiple waves. For example, here we see two waves with amplitudes a and b . When they combine, the superposition state has an amplitude of $a + b$. The relationship is linear. In this next example, where one has an amplitude a and the other has an amplitude $-a$, the superposition is zero. They cancel each other out. Remembering that a physical system can be described by a wave function and Schrodinger's wave equation, their quantum states can be linearly combined like these waves. This is the principle of quantum linear superposition.

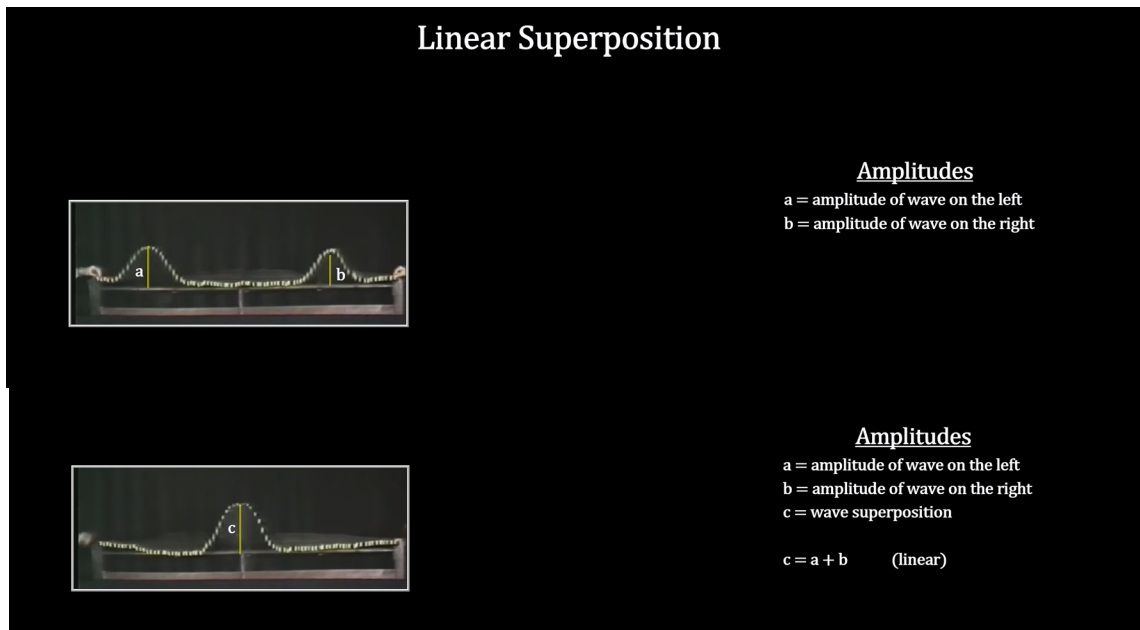

The double slit experiment with photons helps illustrate how this linear superposition works. As light flows through the process, we'll keep track of the quantum state of the photons. We start out with light being passed through a linear polarizer. On exiting the polarizer, we mark the first quantum state as zero for location and V for vertically polarized. As it travels to the double slit, it evolves into a linear superposition state for s_1 and s_2 . It represents the state where it could be at either s_1 or s_2 . [We're not interested in photons that don't make it through either slit.] For photons reaching the screen from s_1 , the state evolves into one that includes coefficient amplitudes that vary for different screen locations. The same is true for photons reaching the screen from s_2 . Only the amplitudes will be different. And, unique to quantum mechanics, photons reaching the screen from the $s_1 + s_2$ state, evolve to a linear superposition of the two (like a wave passing through both).

We square the wave functions to get the probabilities. We see that the probability for hitting any particular point on the screen has 4 components. One is for photons going through s_1 . One is for



photons going through s_2 . And 2 are for the photons going through both. It is the interaction between these two that came from the superposition states on the far side of the double slit that creates the interference pattern.

Double-Slit Experiment

Quantum States

photon quantum state vector at the start
 $|0V\rangle$
 photon quantum state vector at the slits
 $|s_1V\rangle + |s_2V\rangle$
 photon quantum state vector at the screen point n
 $(\Psi_n + \Phi_n)|nV\rangle$
 Where
 Ψ_n and Φ_n are the probability amplitude coefficients
 for starting from s_1 and s_2 respectively

Screen Hit Location Probability

$$P_n = (\Psi_n^* + \Phi_n^*)(\Psi_n + \Phi_n)$$

$$= \underbrace{\Psi_n^* \Psi_n}_{\text{from } s_1} + \underbrace{\Phi_n^* \Phi_n}_{s_2} + \underbrace{(\Psi_n^* \Phi_n + \Phi_n^* \Psi_n)}_{s_1 \text{ and } s_2 \text{ entangled states}}$$

To find out "which-way" a photon went, two quarter wave plates are placed in front of the slits. A quarter wave plate is a special crystal that can change linearly polarized light into circularly polarized light. Plate 1, in front of slit 1, will change the photon's polarization to be clockwise while plate 2, in front of slit 2, will change it to be counter clockwise. These are reflected in the photon's new quantum state where R is for clockwise and L is for counter clockwise. Once the photon reaches the screen, we can measure its polarization and know which slit it went through. But, because the left and right polarized terms are orthogonal, they cancel out when we calculate the probability distribution. We are left with a probability distribution that only contains terms for the two slits giving us the blob instead of the interference pattern. Now if we remove the quarter wave plates, we get back the superposition states and the interference pattern.

Double-Slit Experiment

Quantum States

photon quantum state vector at the start
 $|0V\rangle$
 photon quantum state vector at the slits
 $|s_1R\rangle + |s_2L\rangle$
 photon quantum state vector at the screen point n
 $\Psi_n|R\rangle + \Phi_n|L\rangle$
 Where
 Ψ_n and Φ_n are the probability amplitude coefficients
 for starting from s_1 and s_2 respectively

Screen Hit Location Probability

$$P_n = (\Psi_n^* + \Phi_n^*)(\Psi_n + \Phi_n)$$

$$= \underbrace{\Psi_n^* \Psi_n}_{s_1} + \underbrace{\Phi_n^* \Phi_n}_{s_2} + \underbrace{(\Psi_n^* \Phi_n + \Phi_n^* \Psi_n)}_{s_1 \text{ and } s_2 \text{ entangled states}}$$



In the early days of Quantum Mechanics development, some physicists proposed that linear superposition was appropriate for macroscopic objects and that superposition states only degenerated into base states when the system was ‘observed’ or ‘measured’ implying the need for a human. To counter these misconceptions, Schrodinger, with a bit of humor, proposed a thought experiment now called Schrodinger’s Cat. It went like this: Suppose we had a cat penned up in a box with a tiny bit of a radioactive substance, so small, that in the course of an hour one of the atoms might decay, but with an equal probability that it does not decay. He added a Geiger counter to detect the decay should it happen. The Geiger counter is hooked up to a lever that drops a weight on a glass bottle of hydrocyanic acid should it detect a decay. The released poison gas would kill the cat.

If we were to consider the quantum state of the cat during this hour, we’d say it is in a superposition of alive and dead ($|\text{alive}\rangle + |\text{dead}\rangle$) and this state would persist until we opened the box and the subjective observer-induced collapse of the wave function revealed the state of the cat: alive or dead. Firstly, the idea that life and death could be considered quantum states isn’t right. And secondly, the idea that the cat, if found dead, died when the box was opened is ridiculous. An autopsy could prove that it was dead earlier than that. The real situation has the decaying atom in a linear superposition state of ($|\text{decayed}\rangle + |\text{not-decayed}\rangle$). It’s wave function collapses at decay time when the Geiger counter encounters it. The subsequent observation by a human, records only what has already occurred.

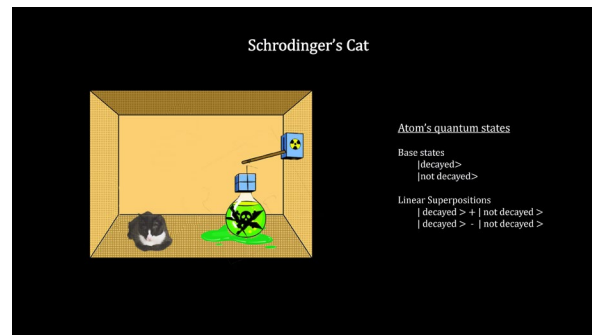
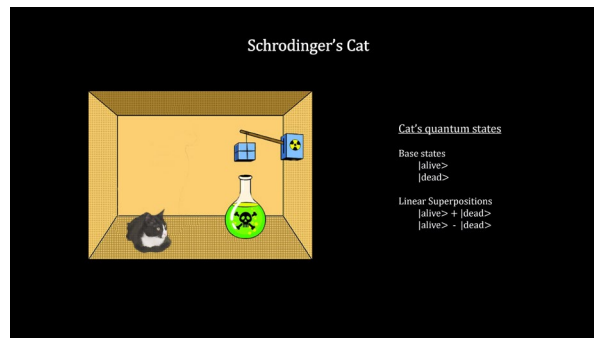



With the understanding that particle base quantum states can and do combine into linear combinations called superposition states, we can examine how these states combine when particles become entangled with each other.

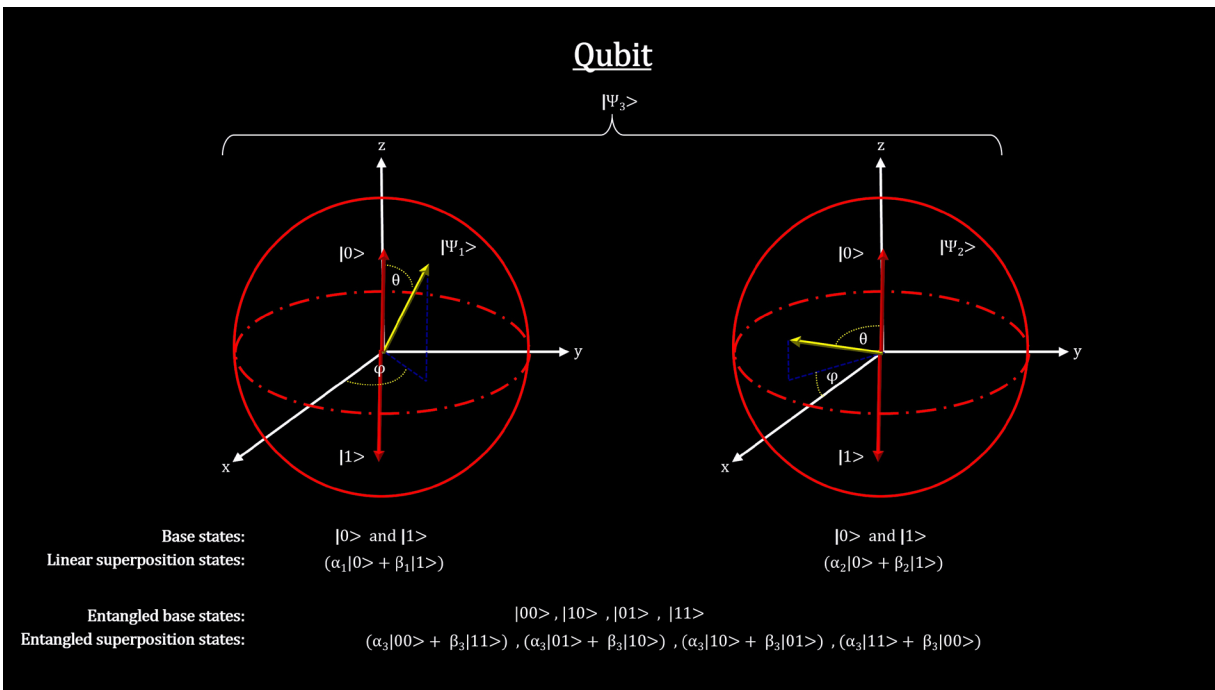

Quantum Entanglement

[Music: Puccini - La Bohème - Musette Waltz]

Here's a water wave. It's described by a wave function that determines its operation and a wave equation that determines the change in the function over time. We can channel this wave into two directions say A and B. With enough time, we can create a great distance between the two branches. If we examine branch A at some time t and find that the wave is at a peak, we will know immediately that at that exact time, the branch B wave will also be at a peak. We don't ask "how did the A branch inform the B branch that it needed to be at a peak". We did not analyze weather information was flowing from A to B faster than the speed of light. We simply note that both branches are a part of a single wave equation that determines its state at any time t. Of course, if we drop channel A's water over a cliff, the wave in channel B will continue on its merry way.



Water Wave

A

Classic Wave Function

$$\Psi(x,t) = A \sin(2\pi x/\lambda - 2\pi vt)$$

Where

- x = distance
- t = time
- A = wave amplitude
- λ = wavelength
- v = wave frequency

$$\partial\Psi(x,t)/\partial t = -A2\pi v \cos(2\pi x/\lambda - 2\pi vt)$$

$$\partial^2\Psi(x,t)/\partial t^2 = -A(2\pi v)^2 \sin(2\pi x/\lambda - 2\pi vt)$$

B

Classic Wave Equation

$$\partial^2\Psi(x,t)/\partial x^2 = v\partial^2\Psi(x,t)/\partial t^2$$

Where

v = wave velocity = $\omega\lambda$

To help isolate the key difference between classical mechanics and quantum mechanics, let's look at one more classical example. Here we start with two coins, each with a heads one side and a tails on the other. If we put them both into a spin and send them up the two channels, we note that during the journey, they exhibit neither heads nor tails. But they carry a probability that, once stopped, they will either come out heads or tails. The probability is 50/50. But unlike the water wave, the results for one of them does not tell us anything about the results for the other. They are independent. But like water waves, the outcomes can be predicted if the starting conditions and channel environment are known. [Items like time and the coin's mass, diameter, rotation rate, starting conditions, air resistance, surface friction etc., enable Newtonian mechanics to predict the outcomes for each of the coins in advance.]

Spinning Coins

A

B

Spinning Coin Equation - Euler's Method

$$x_{n+1} = x_n + h(v \cos \theta)$$

$$y_{n+1} = y_n + h(v \sin \theta)$$

$$\theta = \left[\frac{gd}{R(\mu g + cd/4)} \right] \ln \left[\frac{v_0 + \omega_0 d/4}{v_0 + \omega_0 d/4 - t(\mu g + cd/4)} \right]$$

Where:

- h = $t_{n+1} - t_n$
- t = time
- v_0 = initial velocity
- $v = v_0 - \mu g t$
- μ = coefficient of friction
- g = acceleration due to gravity

Where:

- ω_0 = initial angular speed
- $\omega = \omega_0 - kt$
- k = constant for air resistance
- R = radius of the coin
- d = $R \sin \alpha$
- α = angle of coin from vertical

No heads or tails

No heads or tails



For the quantum mechanics view, we'll start out with 2 electrons that have been put together in a magnetic field to 'entangle them'. Entangled particles are particles that have their quantum states described by a single wave function. The quantum state in question here is the electrons' spin. In their lowest energy state, when one is up, the other will be down. Now we send one of the electrons down channel A and the other down channel B. As they travel, they will not exhibit any spin much like the coins did not exhibit heads or tails. In this example, the moment the electron in channel A interacts with a strong magnetic field such as in a Stern-Gerlach apparatus, it will bring either up spin or down spin to the interaction with (like the coins) a 50/50 probability. At the same instant, the other electron's spin is determined – (like the water wave). If A was up, B will be down. If A was down, B will be up. This is as expected because both particles are following the one wave function.

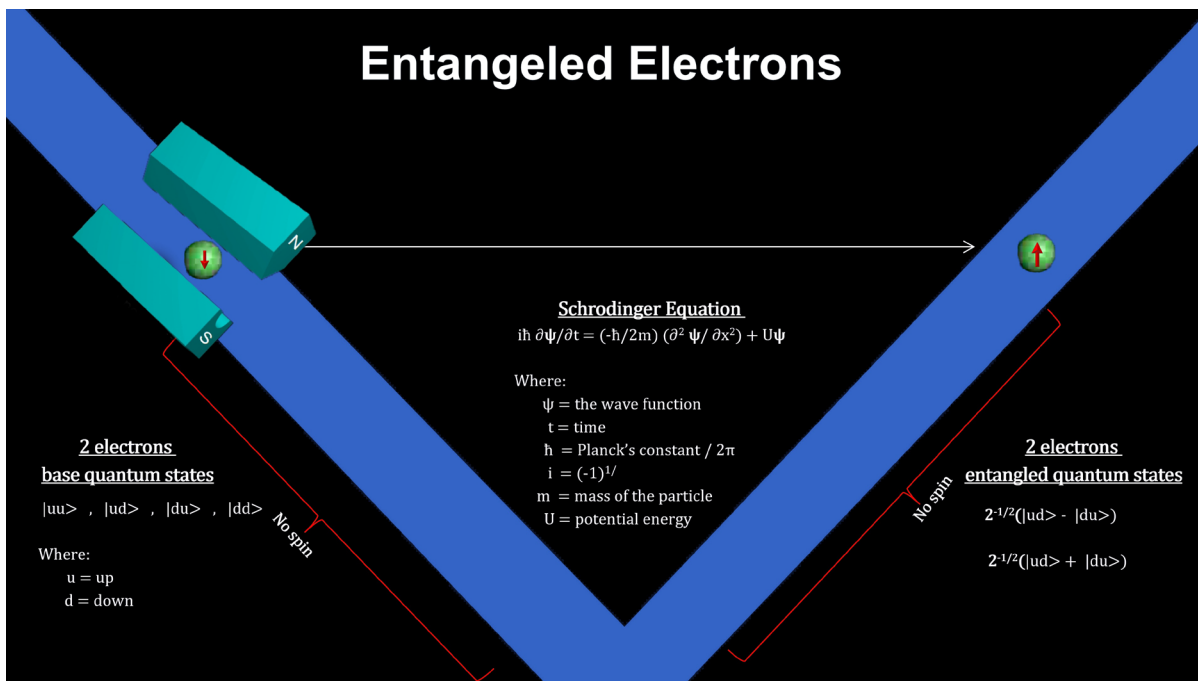

Einstein's Problem with Quantum Mechanics

In 1935, Einstein along with Boris Podolsky and Nathan Rosen argued that quantum mechanics was not 'complete' as a theory. They wrote that:

To be correct, the theory must match what we observe through experiment and measurement. To be complete, every element of physical reality must have a corresponding element in the theory.

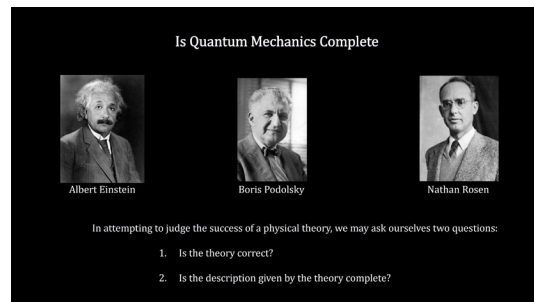



Einstein used the following thought experiment to illustrate this point. Consider two identical entangled particles starting from the same place and moving at the same speed in opposite directions from a common starting point. Letting x represent the distance traveled, x_2 would have the opposite sign as x_1 . Letting p represent particle momentum, and given that the initial momentum was zero, p_2 would have the opposite momentum of p_1 , so their sum would be zero. That each particle has a location and a momentum means that these quantities are elements of a physical reality.

Heisenberg's Uncertainty principle rules out the ability to measure these two quantities at the same time for any one particle because interacting with one impacts the ability to measure the other. But, according to Einstein, measuring x_2 allows us to predict x_1 . And measuring p_1 allows us to predict p_2 . With this, we can know both the position and momentum of both particles at the same time.

According to Einstein, this is how a 'complete theory' would work. But in quantum mechanics, given that these two particles are under a single wave function, measuring x_2 impacts x_1 in such a way as to make it impossible to measure p_1 . From Einstein's point of view, this was 'spooky action at a distance' and made Quantum mechanics 'incomplete'.

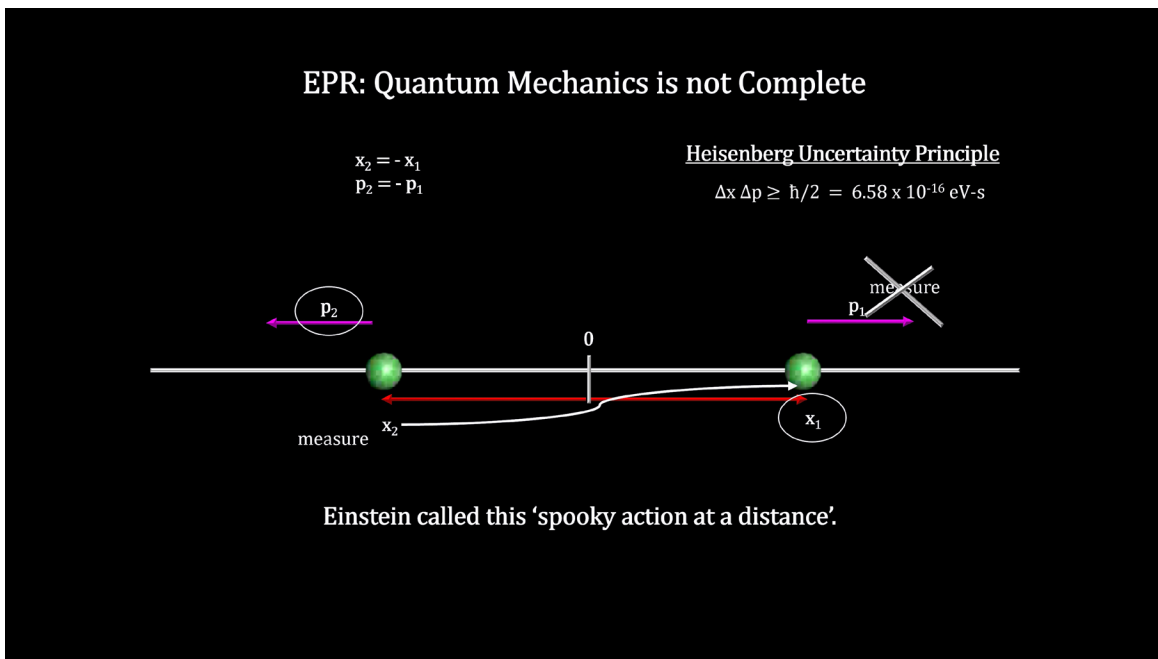

Einstein proposed that there are 'hidden variables' at play that determine the state of particles like these, in advance. One of his examples went like this. Suppose we have a pair of gloves; one is right-handed and one is left-handed. We place them in two identical boxes and mix up the boxes to the point where we do not know which glove is in which box. Now send these two boxes down the channels A and B. As soon as you open one and find out which handedness it has, you immediately know the other. He thought that someday, a new physics theory will uncover these currently hidden variables.

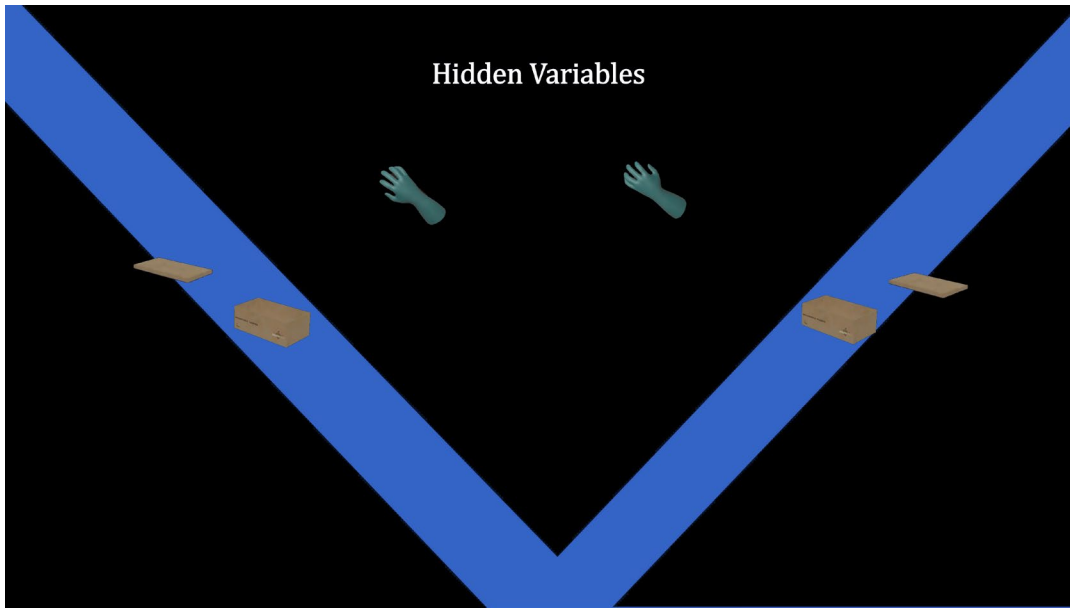

Niels Bohr responded with support for quantum mechanics. In his view, reality follows the wave nature of matter without any need for ‘hidden variables’. At the time, there was no way to prove whether ‘hidden variables’ did or could not exist. In fact, how can you even go about ‘proving’ that a ‘hidden’ variable doesn’t exist.

Bohr: Quantum Mechanics is Complete

Schrodinger Equation
$$i\hbar \frac{\partial \psi}{\partial t} = (-\hbar^2/2m) (\partial^2 \psi / \partial x^2) + U\psi$$

Where:
 ψ = the wave function
 t = time
 \hbar = Planck's constant / 2π
 i = $(-1)^{1/2}$
 m = mass of the particle
 U = potential energy



Bell's Inequality

In 1964, an Irish physicist, John Bell, published a mathematical paper proposing a way to test for hidden variables. His work is called “Bell’s Theorem” or “Bell’s Inequalities.” It was based on entangled electrons and Stern-Gerlach apparatus spin detectors. But we’ll use the more easily managed particle – photons and polarized lenses.



Bell’s idea was to assume Einstein’s ‘hidden variables’ hypothesis is true, and then show how it leads to a contradiction. This would prove that the ‘hidden variables’ hypothesis is false.

Pythagorean Theorem

$$a^2 + b^2 = c^2$$

Let $a = b = 1$
Then $1^2 + 1^2 = c^2$
 $2 = c^2$
 $\sqrt{2} = c$

Proof by Contradiction Example

Assume $\sqrt{2}$ is a rational number

Then, by definition there must exist 2 numbers p and q with no common factors such that $p/q = \sqrt{2}$

Then $p^2/q^2 = 2$
 $p^2 = 2q^2 \Rightarrow q$ is an even number (it has the number 2 as a factor)

Let $q = 2r$

Then $(2r)^2 = 2q^2$
 $4r^2 = 2q^2$
 $2r^2 = q^2 \Rightarrow q$ is an even number (it also has the number 2 as a factor)

This is in contradiction with p and q not having any factors in common
Therefore, no such numbers p and q exist so the assumption that $\sqrt{2}$ is rational is false
We have proven that $\sqrt{2}$ must be an irrational number

The best way to understand Bell’s Theorem is to use Venn diagrams from basic set theory. Here’s a simple Venn diagram example. Consider the set of all people in a town, say Paris, Illinois who go out on a particular rainy day wearing a hat. Some of these people are also wearing gloves. This would be a subset of the whole. Now we count the number of people with hats and we count the number of people with hats and gloves. If the number of people with hats and gloves is greater than the number of people with hats, you have a contradiction – a violation of the basic assumption. The assumption that you are counting people in the same town on the same day must be false. For example, this violation could happen if the count for hats was indeed taken in Paris, IL, but the count of hats and gloves was taken in Paris, France.



Venn Diagrams

Contradiction

Assumption
 a = set of people in Paris, IL wearing hats
 b = set of people in Paris, IL wearing hats and gloves

Let
 N(a) = number of people in set a
 N(b) = number of people in set b

We must have
 $N(a) \geq N(b)$

If the counts turn out to have $N(b) > N(a)$ we have a contradiction.

For example
 If $N(a) = 457$ and $N(b) = 72,654$
 then both counts cannot be from Paris, IL on the day in question

Bell's thought experiment involved sending photons through polarized filters. If a photon passes through a filter, it is referred to as 'passed'. If it's blocked, it's referred to as 'failed'. The probability that a photon will pass or fail depends entirely on the angle between its polarization state and the filter's.

Photon Pass/Fail Probability

$$P_p = \cos^2 \theta$$

$$P_f = \sin^2 \theta$$

$$P_p + P_f = 1$$

$$\cos^2 \theta + \sin^2 \theta = 1$$

Where

- P_p = probability of passing
- P_f = probability of failing
- θ = polarization angle
- $|\theta\rangle$ = quantum state
- $|0^\circ\rangle$ = unit vector - vertical
- $|90^\circ\rangle$ = unit vector - perpendicular

Here we have three tests: A, B and C. Test A sends vertically polarized photons into a vertically polarized filter. Test B sends vertically polarized photons into a filter polarized at an angle θ . And test C sends vertically polarized photons into a filter polarized at an angle 2θ .

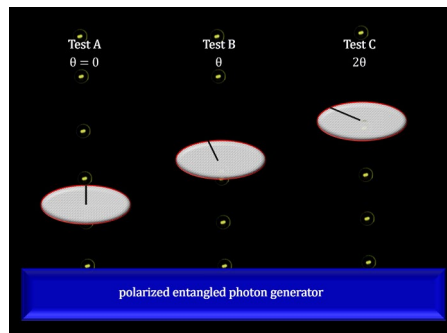



Now the object of the exercise is to examine the role of Einstein’s entangled particle ‘hidden variables’ hypothesis, so we’ll use quantum entangled photons along with the assumption that interacting with one of them does not change the state of the other. So, all tests start out with vertically polarized entangled photons.

The thought experiment used tests in 3 particular combinations. One was to run a photon through test A followed by running it’s entangled photon through test B.

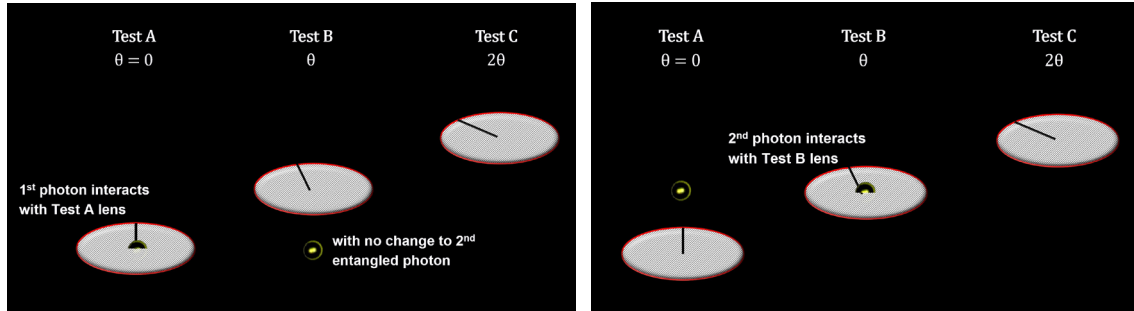

The second was to run a photon through test B followed by running it’s entangled photon through test C.

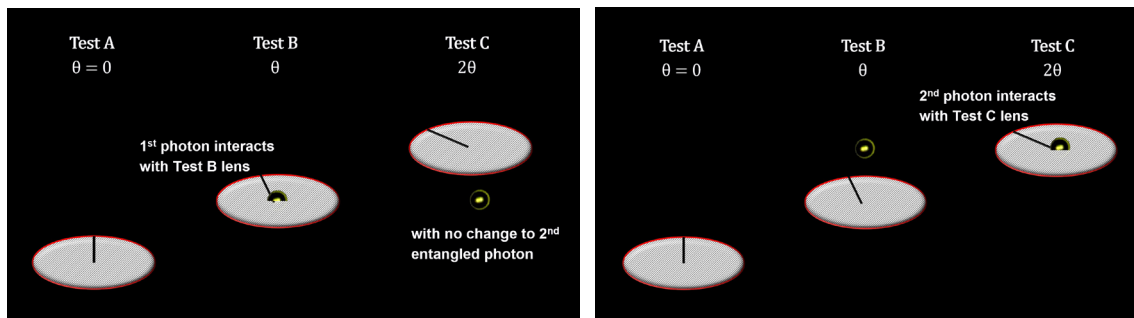

And the third was to run a photon through test A followed by running it’s entangled photon through test C.

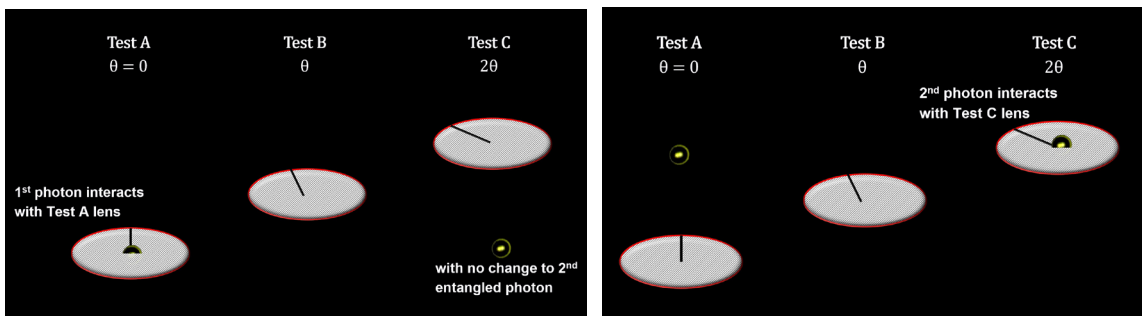



What Bell was looking for are the number passing test A followed by failing test B called (AnotB); the number passing test B followed by failing test C called (BnotC); and the number passing test A followed by failing test C called (AnotC).

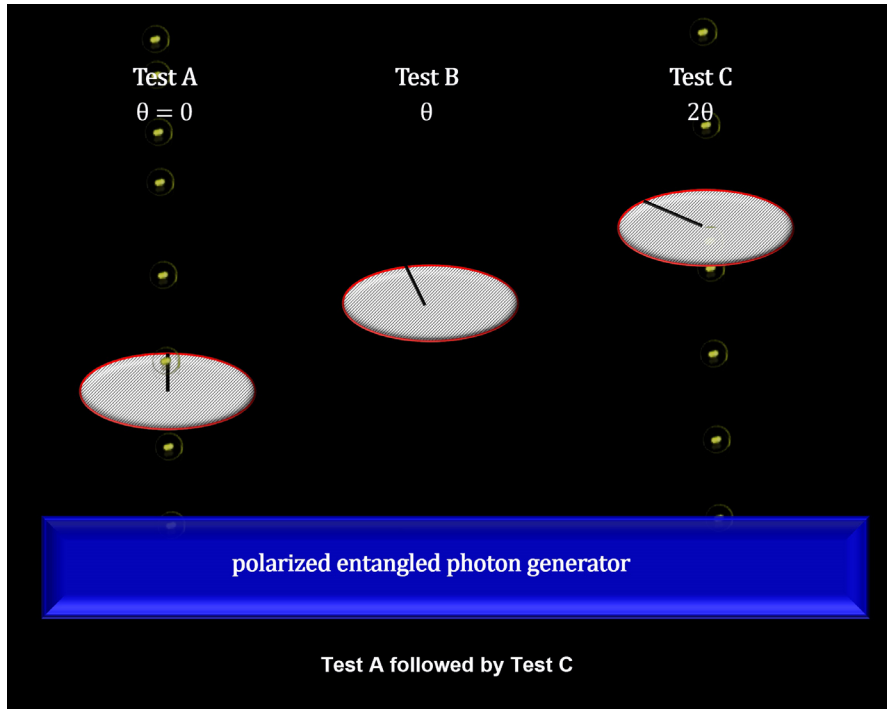

Now consider the 3 sets: set A of all the tests that passed test A, set B of all the tests that passed test B, and set C of all the tests that passed test C. Notice where they overlap and where they don't. Here's the subset (A not B) and (B not C). When we combine them, you can see that 'A not C' is a subset. From set theory we know that the number in (A not B) + the number in (B not C) must be greater or equal to the number in (A not C). This is the famous Bell Inequality.

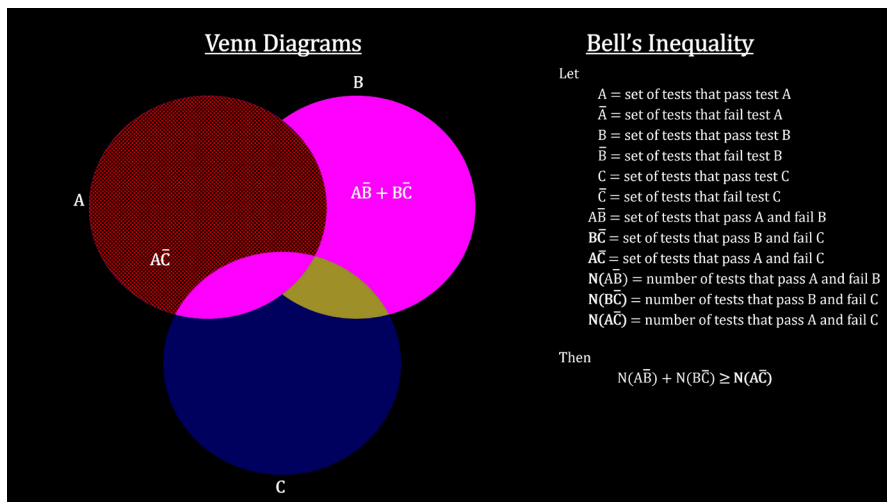



Remember that our assumption is that the states of the entangled particles depend only on their original ‘hidden variables’ and cannot change just because there was a measurement taken on the other particle. The testing was done with θ equal to 22.5 degrees.

We cannot yet entangle more than 2 particles, so the tests were done in three phases. In the first phase, they sent 100 vertically polarized entangled photons into vertically polarized lens A. All 100 passed through: $N(A) = 100$. None were blocked: $N(\text{not}A) = 0$. The entangled photons then entered lens C polarized at 45 degrees. 50 passed through: $N(C) = 50$. And 50 were blocked: $N(\text{not}C) = 50$. So, the number in A not C was 50.

In the second phase, they sent 100 vertically polarized entangled photons into vertically polarized lens A. And, as before, all 100 passed through: $N(A) = 100$. The entangled photons then entered lens B polarized at 22.5 degrees. 85 passed: $N(B) = 85$. And 15 were blocked: $N(\text{not}B) = 15$. So, the number in A not B was 15.

In the third phase, they ran 100 vertically polarized entangled photons into lens B polarized at 22.5 degrees. 85 passed through: $N(B) = 85$. And 15 were blocked: $N(\text{not}B) = 15$. The entangled photons then entered lens C polarized at 45 degrees. 85 passed: $N(C) = 85$. And 15 were blocked: $N(\text{not}C) = 15$. So, the number in B not C was 15.

$$N(\text{AnotB}) + N(\text{BnotC}) \text{ is greater than or equal to } N(\text{AnotC}).$$

$$15 + 15 \geq 50$$

Bell’s inequality equation reads that 30 is greater than or equal to 50, which is false. So, the assumption that a changed entangled electron has no impact on its entangled partner is false. Therefore, there are no ‘hidden variables’ as Einstein had proposed.

Bell's Inequality

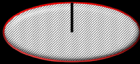
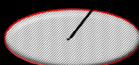
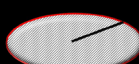
<p>Test A $\theta = 0$</p> 	<p>Test B 22.5°</p> 	<p>Test C 45°</p> 
---	---	---



polarized entangled photon generator

$N(\overline{A\overline{B}}) + N(\overline{B\overline{C}}) \geq N(\overline{A\overline{C}})$

We measure

$N(\overline{A\overline{C}}) = 50$

$N(\overline{A\overline{B}}) = 15$

$N(\overline{B\overline{C}}) = 15$

Therefore

$N(\overline{A\overline{B}}) + N(\overline{B\overline{C}}) \geq N(\overline{A\overline{C}})$

$15 + 15 \geq 50$ False



Today we can produce entangled photon pairs in large numbers. We can even see the states of entangled particles change.

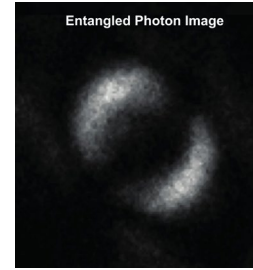

Quantum Ghost Images

[Music: Svendsen - Romance in G]

In 2019, a team of physicist at the University of Glasgow devised an actual experiment that used ‘ghost images’ to prove quantum entanglement. First, we’ll cover what a ghost image is and how one is created. Then we’ll cover how they proved quantum entanglement via a Bell Inequality. Here we have an argon laser sending its output into a beta-barium borate crystal. These are unique crystals in that they can turn a photon into two entangled photons. The process is called ‘spontaneous parametric down-conversion’. A beam splitter separates the photons. One, called the ‘idler’ proceeds through a liquid crystal spatial light modulator. There are many types of such modulators. This one has a thin gold image of the Greek letter ‘lambda’ imbedded in silicon. Given the idler photons’ wavelength, they will pass through gold and be blocked by silicon. The photons that do pass through enter a single photon detector. This detector then sends a signal to the camera. For each photon that travels to the spatial modulator, its entangled counterpart, called the ‘signal photon’ is guided to an intensified charge-coupled device camera. This is the kind of camera technology we see in modern telescopes. We cover how they work in the ‘How far away is it’ video book chapter on ‘Planetary Nebula Exploding Star’. There is a delay loop in the photon’s path to ensure that it enters the camera at exactly the same time that its entangled counterpart’s signal reaches the camera, if indeed it passed through the modulator. The match of one photon with one signal is called a coincidence count. When the camera senses a photon and a signal simultaneously, it lights the corresponding image pixel. If the camera gets a photon without a signal, it ignores it. As you can see, over time, the ‘lambda’ image is constructed. This is called a ‘ghost image’. The light that creates it never encountered the object itself.

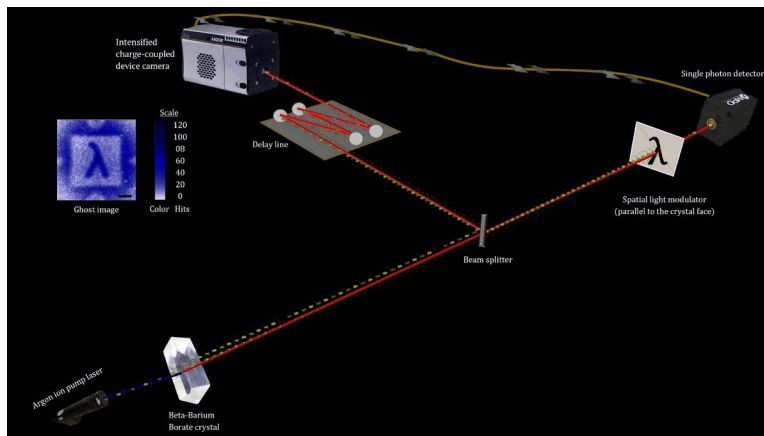



To ghost image a photon’s polarization, the Glasgow team made some adjustment to this configuration to take advantage of the entangled polarization and the entangled orbital angular momentum created by the Beta-Barium Borate crystal. First, the image in the special modulator is replaced with what they call a ‘phase object’ that covers the outer edge of photon phase plane. This highlights the region of interest. If we ran with just this change, we’d see this ghost image.

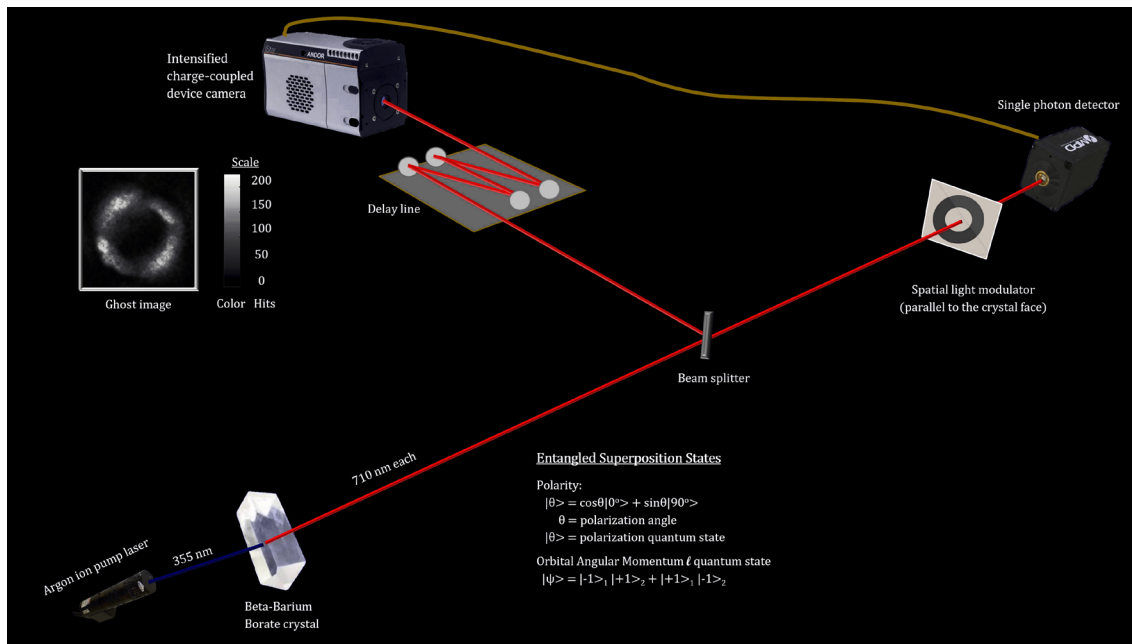

The next step is to introduce a second spatial modulator on the ‘signal’ path of the photon heading to the camera. If the first angle is 0, we get this base image.

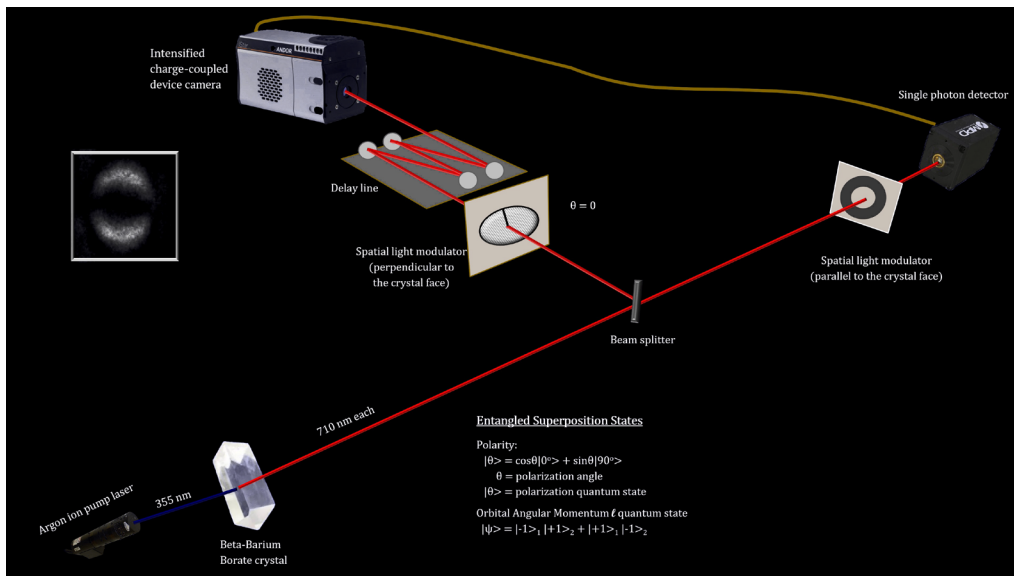



If we change the angle with a new special modulator, say one with a 45° angle the orientation of the image changes accordingly. This was done for 90° and 135°.

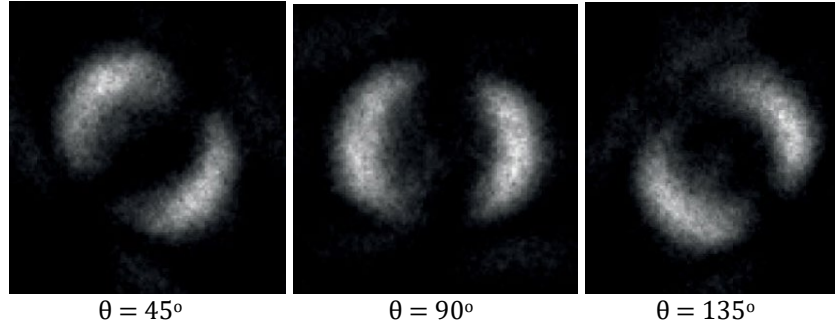

Now the key to the experiment is that there is a relationship between the angular momentum of the photon and its orientation that shows itself in the light intensity profile – measured as the number of coincidence counts. In other words, the intensity features of the ghost image

reveal entanglement. The counts show a Bell violation – proof that there are no hidden variables.

Bell Violation

Classical physics $|S| \leq 2$

Were

$$S = E(\theta_1, \theta_2) - E(\theta'_1, \theta_2) + E(\theta_1, \theta'_2) + E(\theta'_1, \theta'_2)$$

$$E(\theta_1, \theta_2) = \frac{C(\theta_1, \theta_2) + C(\theta_1 + \pi/2, \theta_2 + \pi/2) - C(\theta_1 + \pi/2, \theta_2) - C(\theta_1, \theta_2 + \pi/2)}{C(\theta_1, \theta_2) + C(\theta_1 + \pi/2, \theta_2 + \pi/2) + C(\theta_1 + \pi/2, \theta_2) + C(\theta_1, \theta_2 + \pi/2)}$$

$C(\theta_1, \theta_2)$ = recorded counts when the first photon is detected after orientation θ_1 and when the second photon is measured after orientation θ_2 .

Test results

$|S| = 2.443 \geq 2$ a Bell Violation

Therefore, we see that the entanglement is real, but it is not ‘spooky action at a distance’ as Einstein proposed. It is just the wave nature of reality as Bohr and proposed.

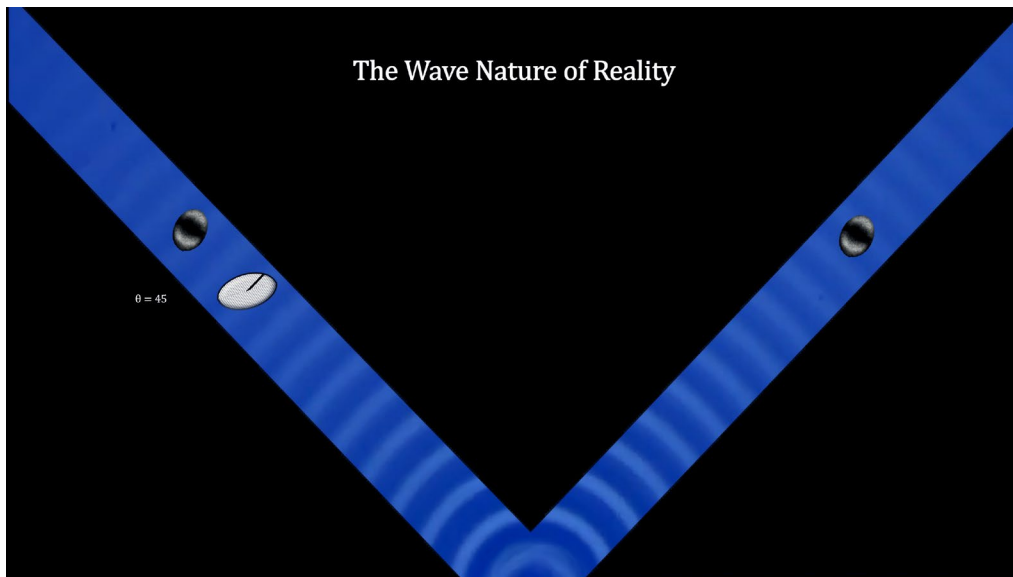



Quantum Eraser Experiment

The following quantum eraser experiment was conducted by a team of physicist [S. P. Walborn, M. O. Terra Cunha, S. Padua, and C. H. Monken] at the Brazilian federal Universidad in Minas Gerais (mee·naas zhr·ise). It starts with the normal ‘double slit’ experiment like we saw earlier, but uses counters instead of a florescent screen to develop the interference patterns. Here we have a laser that feeds a Beta-Barium Borate crystal to create two entangled linearly polarized photons sent off in two directions. In this experiment, we call one direction p and the other s . The photons that go down path p are called p photons and those that go down s are called s photons. We’ll label their linearly polarized quantum states x and y . Because they are entangled, they will travel with probabilities for these states without actually exhibiting them – much like the spinning coin’s heads and tails. But we know that if the p photon is found to be in state x , then we know the s photon is in state y and vice versa. The p photons go directly to a single photon detector D_p . The detector registers the photon and sends a signal to a coincidence counter. The s photons go through a double slit. But instead of hitting a florescent screen, some enter a moveable single photon detector D_s . When it detects a photon, it too sends a signal to the coincidence counter. Once the Coincidence counter receives this second signal, a ‘count’ is recorded. The counts are tallied for 400 seconds. Then the detector is moved a millimeter and the number of counts in a 400 second interval is recorded for the new detector position. This is repeated until the detector has scanned across a region equivalent to the screen in a normal double slit experiment. The results are displayed by plotting the number of counts as a function of the detector’s position. The interference pattern is clearly observed. As we did with the double-slit experiment, we keep in mind the quantum state of the particles, both initial and after the s photon passes through the double slit. Remember that it is the interaction between the two superposition states on the far side of the double slit that creates the interference pattern.

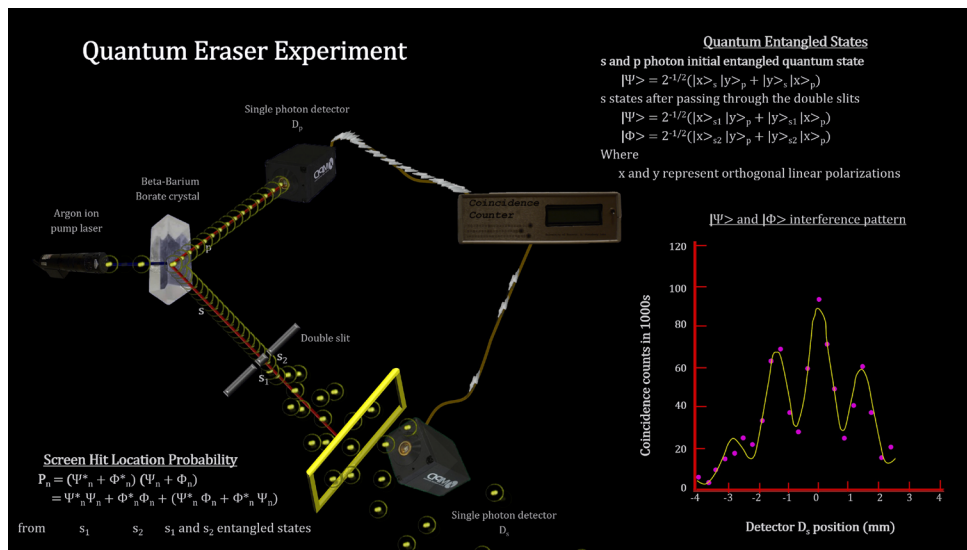



Like we did to provide ‘which-way’ information in the double slit experiment, we put quarter wave plates in front of each slit. Measuring the polarization at the detector tells us which slit the photon went through. Given the + or - 45° shifts created by the quarter wave plates, the two superposition states cancel each other out. We are left with just the two particle like probabilities. When the coincidence counts were tallied at each detector location, it was found that indeed the interference pattern was gone.

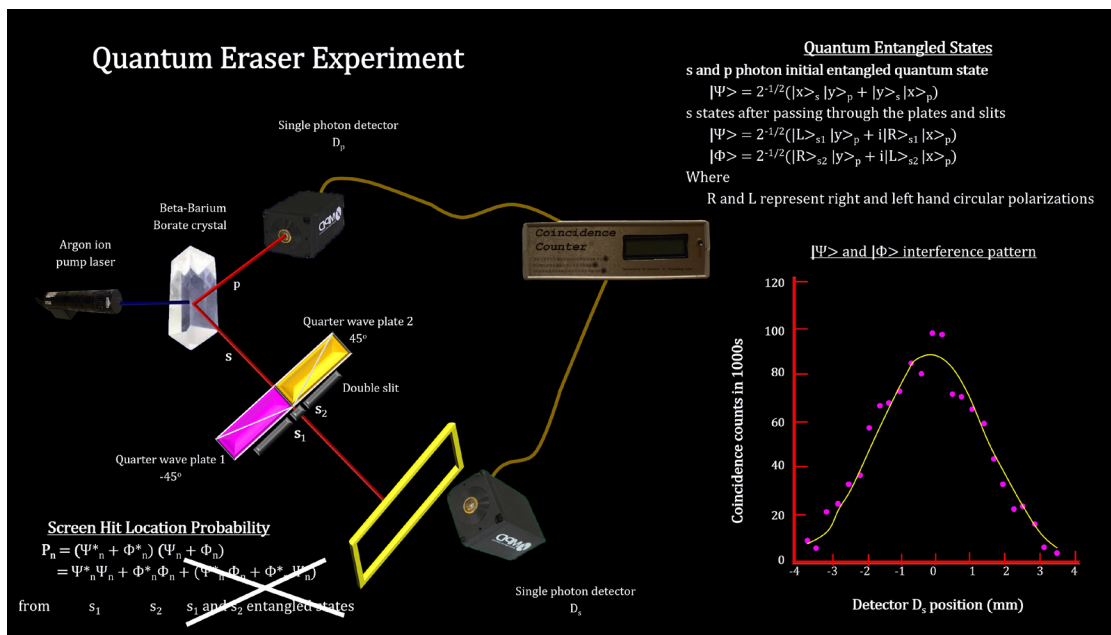

In order to regain an interference pattern, we place a polarizer in the p beam closer to the source crystal than the quarter wave plates oriented-at +45° (the same as plate 1) or -45° (the same as plate 2). This changes the p photon’s state. The entangled s photon is modified as well, but maintains its linear polarity. Therefor it will still be turned into left or right circular polarity by the wave plates, and therefor still eliminate the interference pattern generating quantum state terms, and therefor still create the ‘blob’ rather than an interference pattern. But now we will no longer ‘count’ all the detected s photons. We count only the ones that corresponded to p photons that make it through the polarization filter. This will produce an interference like pattern that reflects what is going on with the p photons This is called a ‘fringe’ pattern.

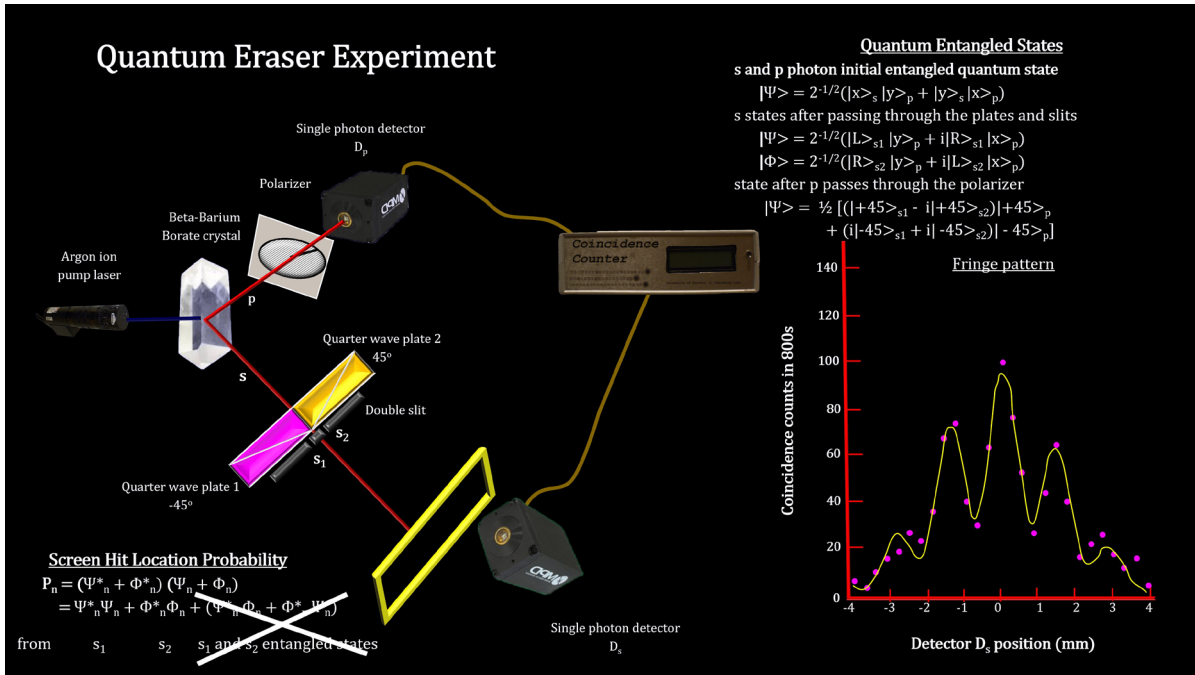

When we do a run with the filter at -45° , we get the ‘anti-fringe’ pattern. Superficially, it looks like the situation that prevented interference has been erased. That is why this is called the ‘quantum eraser’. But in fact, we see that nothing has been erased. When we add these two together, we get exactly the blob image we’ve created ever since we added the which-way information.





You may have already noted that having the p photon reach the polarizer before the s photon reaches the double slit is irrelevant. The exact same behavior happens if the s photon passes through the double slit before the p photon hits the filter or after. Again, fringe and anti-fringe patterns are produced. This setup is made to look like interacting with the p photon changed what happens to the entangled s photon in the past! This has been given its own name ‘delayed quantum eraser’ even though nothing has been erased. Many eraser experiments use beam splitters and adjusted path lengths to turn the blob into fringe and ant-fringe patterns. Either way, I find it very sad that some physicists characterize this experiment as an example of the cause coming after the effect.

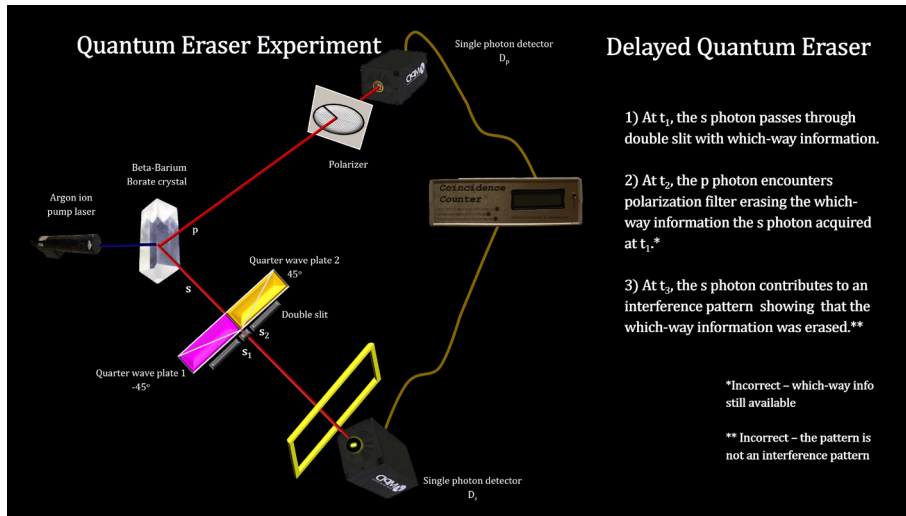

Quantum Computing

Developing experiments without loopholes to prove that the entanglement phenomenon is real has always been difficult. But there’s nothing like actually using a phenomenon to remove all doubt. Quantum computing is doing just that for quantum linear superposition and entanglement. There is an amazing amount of work around the world going into the development of quantum computers and their subsystems. Here’s just 3 of them. The superposition states and quantum entanglement covered in the preceding segments represent the foundational physics for quantum computing. In order to illustrate how this is the case, we’ll actually construct a two-electron quantum computer.

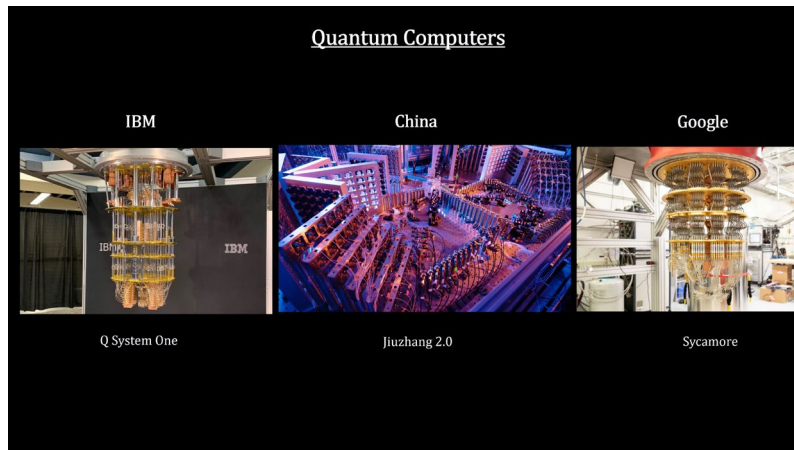



The key difference between classical computers and quantum computers starts with their basic unit of information. For classical computers it is the bit with 2 values per bit 0 or 1.



Quantum computers use quantum bits or qubits for short. And because of quantum linear superposition, a qubit has 4 values. For example, here’s a state vector for the spin of an electron. It’s position is determined by two angles that define its state. This state can be divided into 2 base states and 2 superposition states for a total of 4 – twice the number of possible values for classical bits. What’s more, because of quantum entanglement, every time we add a qubit, we double the number of classical bits the entangled whole can represent.

[Going just a little deeper, we can start with Schrodinger’s wave equation for the system. In quantum mechanics, a particle is represented by a wave function, Ψ . For electron spin, a quantum state for this function can be represented as a vector. When we put in coordinates, we get an angle from the vertical θ , and an angle on the x-y plane φ . We can construct two base vectors $|0\rangle$ and $|1\rangle$ where $|0\rangle$ is up and $|1\rangle$ is down along the vertical axis. The quantum state $|\Psi\rangle$ can be expressed as a combination of these two base states with appropriate coefficients that represent ‘amplitudes’. These amplitudes give us probabilities when the states are squared. These are the superposition states.]

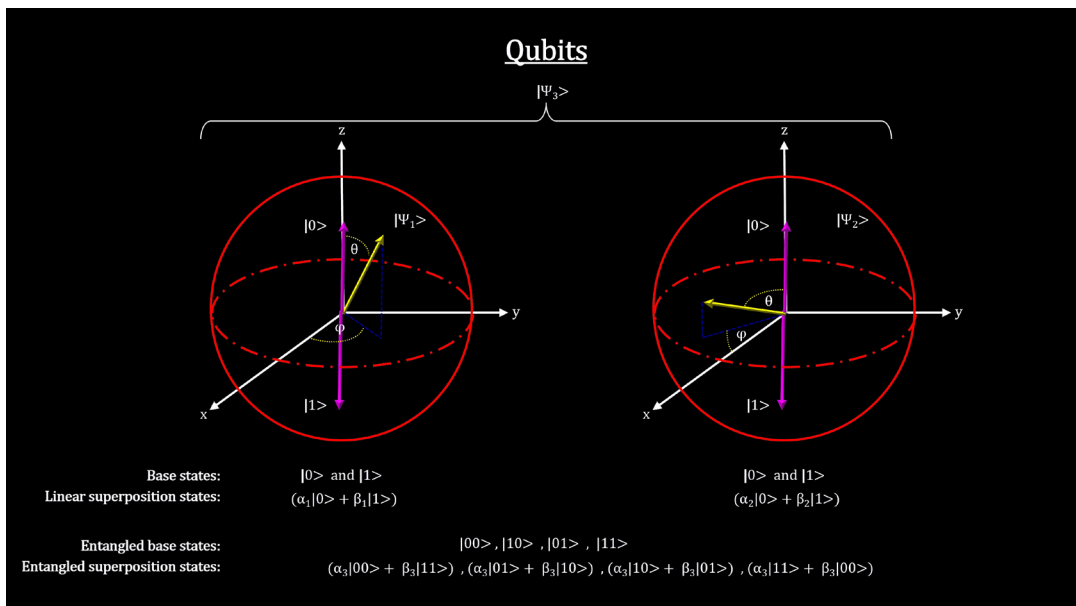



Here’s a table that compare classical computer bits to qubits. 3 qubits are equivalent to 8 bits - a full byte. This scaling grows into significant numbers as the number of qubits are increased. The real impact comes when we start talking about hundred or even a thousand qubits. This exceptional scaling for the qubits has a significant impact on the time computer operations will take. For example, let’s assume we have a computer with a clock speed of 3 GHz. It could perform 3 billion operations per second. Let’s also assume one operation on one bit or qubit can be done in one clock cycle. These numbers are a little optimistic but they provide an order of magnitude estimate. This scaling potential is what’s motivating the development of quantum computers.

Bit vs Qubit Scaling

# of qubits	# classical bits	memory needed	quantum computer time	classic computer time
1	2	2 bits		
2	4	4 bits		
3	8	1 byte		
4	16	2 bytes		
5	32	4 bytes		
10	1024	128 bytes		
20	1048576	128 kB	6.7×10^{-6} s	3.5×10^{-6} s
23	8388608	1 MB	7.7×10^{-6} s	2.8×10^{-6} s
33	8589934592	1 GB	1.1×10^{-5} s	2.9 s
43	8.8×10^{12}	1 TB	1.4×10^{-5} s	49 mins
53	9.0×10^{15}	1 PB	1.8×10^{-5} s	35 hours
63	9.2×10^{18}	1 EB	2.1×10^{-5} s	97.5 years
1000	1.1×10^{301}	1.3×10^{922} EB	3.3×10^{-5} s	1.1×10^{284} years

The current estimate for the age of the Universe is 1.38×10^{10} years. At 3 billion bits processed per second, this many bits takes more than an octillion times longer than the age of the Universe.

A bit has to be able to have its settings of 0 or 1 set or changed and have these settings persist over time. It’s setting must also be detectable. In classical computers, bits are made of transistors. For a transistor, the absence of a voltage on its control line stops current from passing through - making it ‘off’ or = 0. An applied voltage will trigger a current making it ‘on’ or = 1. These values are easily set, changed, and read and once set they persist for as long as needed.

Classic Silicon Bit

Transistor

If power source 2 is weak, no current will flow through the transistor. The transistor is said to be off. This is represented by '0'.

If power source 2 is strong enough, current will flow through the transistor. The transistor is on. This is represented by '1'.

Setting persist, and current flow or no flow makes the setting observable.



There are a number of ways to create quantum bits: atoms, photons, superconductors etc. Silicon spin qubits are also promising. A number of companies are working on them. As of early 2022, Intel appears to have the lead with a 26-qubit product. The long-term goal is to reach a million.

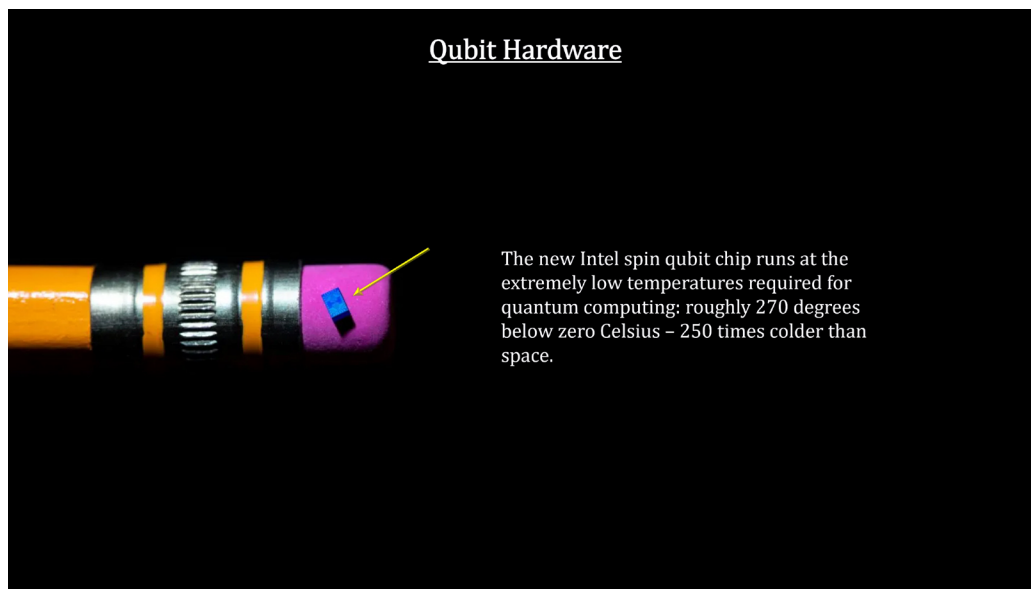

To understand how quantum superposition and entanglement are used, we'll construct a quantum computer out of two electron spin qubits. We start with three layers of silicon. The yellow layer in the middle is made of 'stretched' silicon. It is actually stretched. The distance between the atoms is increased making it easier for electrons to move around. Electrons in this layer will not move up or down into the more compressed silicon without a push.

On top of the silicon, we construct an electronically controlled lattice of gates. Negatively biased electrostatic gates (in gray) and positively biased gates (in brown) are organized to create two energy wells capable of holding two electrons in place. These two wells are called quantum dots. On top of these two components, we add a micromagnet to create a tapered magnetic field. This field couples electron spins to the electric field set up by the gates. With this configuration, we can introduce two electrons.

The states of these electrons are controlled by microwave and voltage pulses applied to the gates by the Quantum Computing Unit. For example, electron spin can be aligned with the magnetic field in the up or down direction. And the two electrons can also be put into an entangled state by managed exchange interactions across the Coulomb barrier between them.

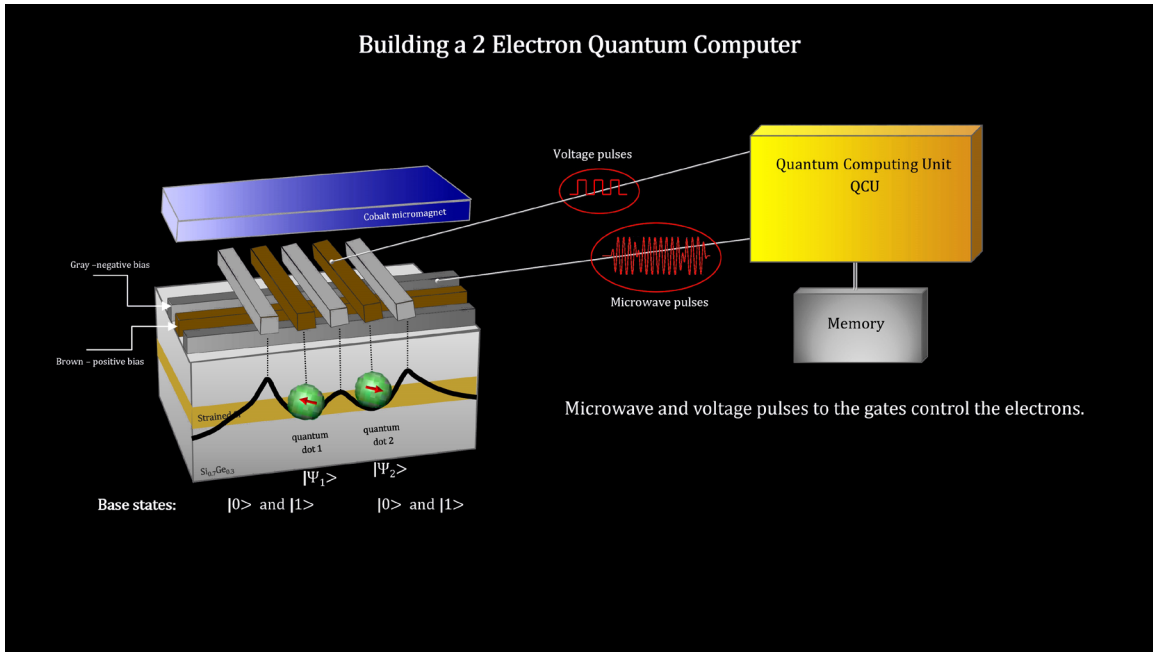

An important operation is called the Hadamard Gate. It takes in a single qubit in a base state as input and outputs a Qubit in a superposition state with equal coefficients. [That would be a state where, if measured, it has a 50–50 chance of either being a 1 or a 0.] This qubit can then be used in further calculations.

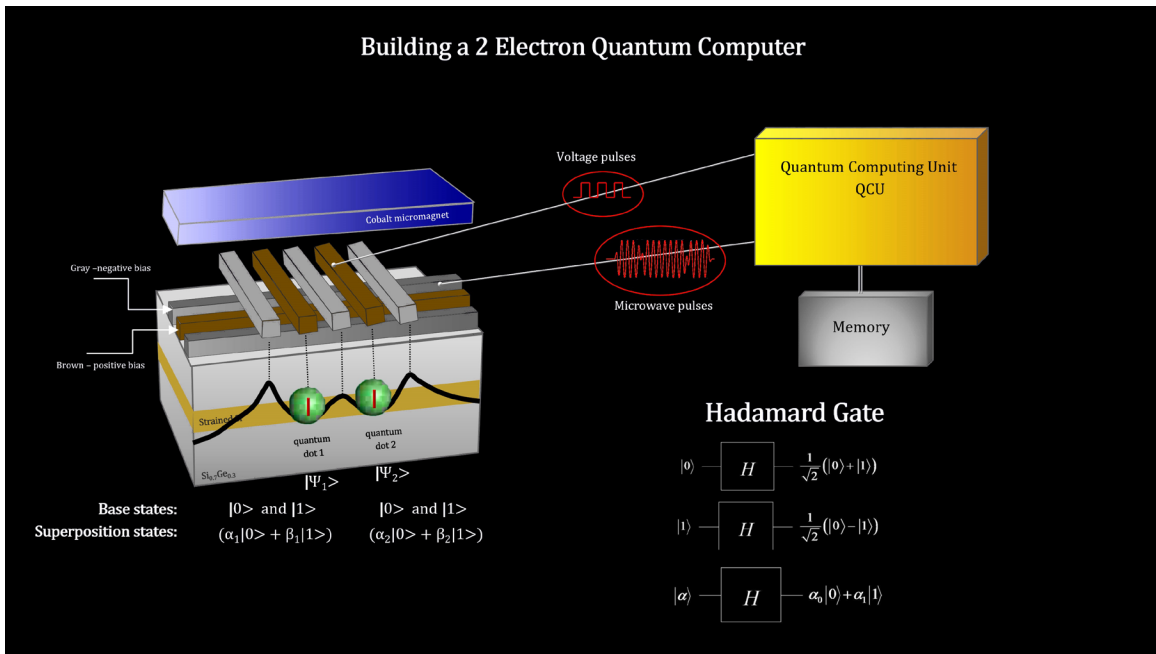



The Controlled NOT gate or CNOT Gate is heavily used. It takes in 2 Qubits and only flips the second Qubit called the target from $|0\rangle$ to $|1\rangle$ or $|1\rangle$ to $|0\rangle$ if the first Qubit called the control is $|1\rangle$. Otherwise, it leaves the target unchanged. Taking advantage of the fact that up = 0 has a slightly lower energy than down = 1, a series of microwave pulses will flip the target qubit only when the control qubit had enough energy to have measured as a 1. This is the function of CNOT and it is done without reading the control qubit. Like changing a photon's polarity, this can be done for any number of entangled qubits without disturbing the entanglement state. This is the case for all quantum gates.

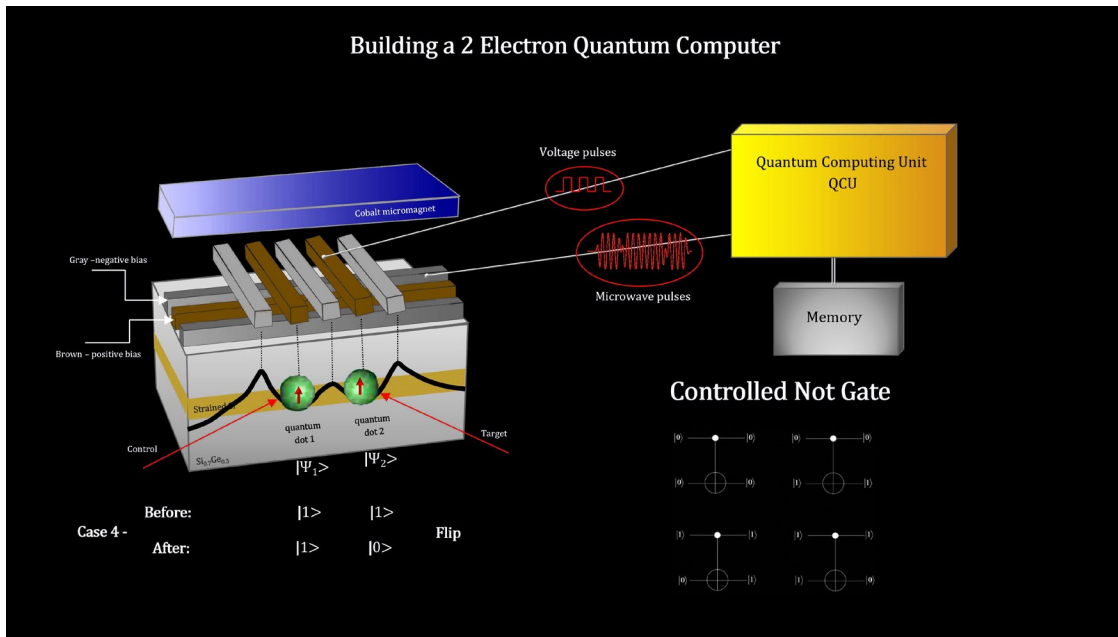

Measurement is a special type of operation done on qubits at the end of a series of gate operations to get the final values. In a magnetic field, electrons have two discrete energy levels based on their spin. [Spin up has a lower energy level than spin down.] Detecting these energy levels tells us what the spin was. Compared to the gates, Measurement is irreversible and hence, is not actually a Quantum Gate. It's execution removes the qubit from its entangled superposition state into a 0 or a 1. The results of a measurement are always stored in classical computer bits for analysis.

[A magnetic field is applied to split the spin-up and spin-down states by the Zeeman energy. The dot potential is then tuned such that if the electron has spin-down arrow, it will leave, whereas it will stay on the dot if it has spin-up. The spin state has now been correlated with the charge state, and measurement of the charge on the dot will reveal the original spin state.]

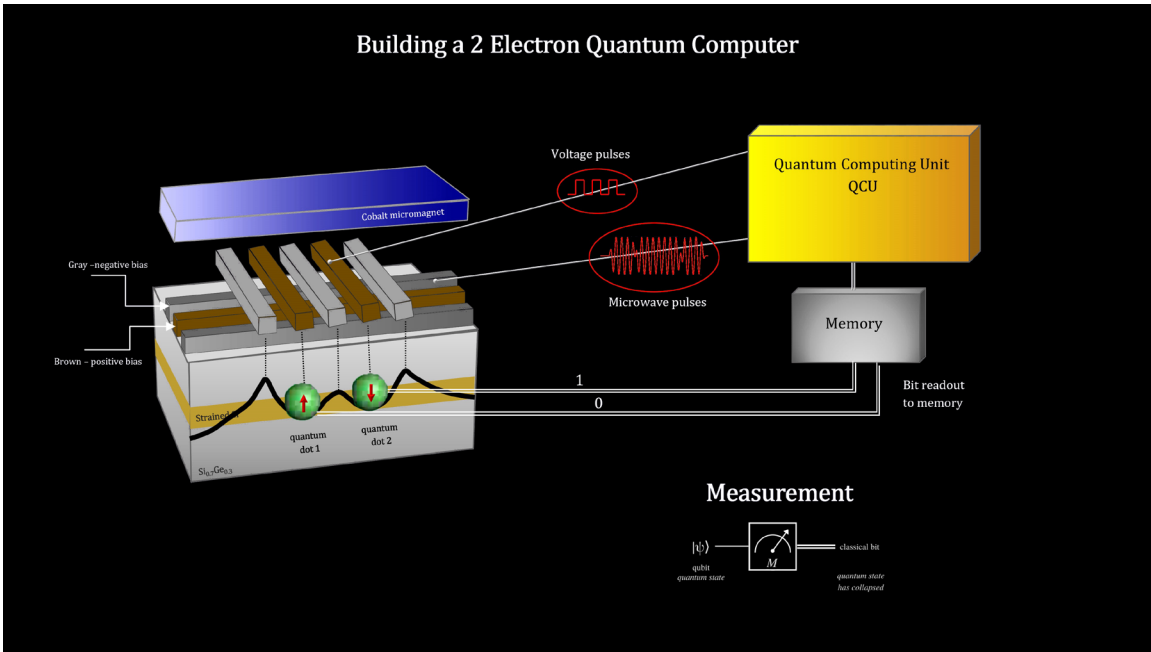

Combinations of quantum gates are called quantum circuits that combine to execute computer instructions. This is a 2 electron-spin qubit quantum computer.

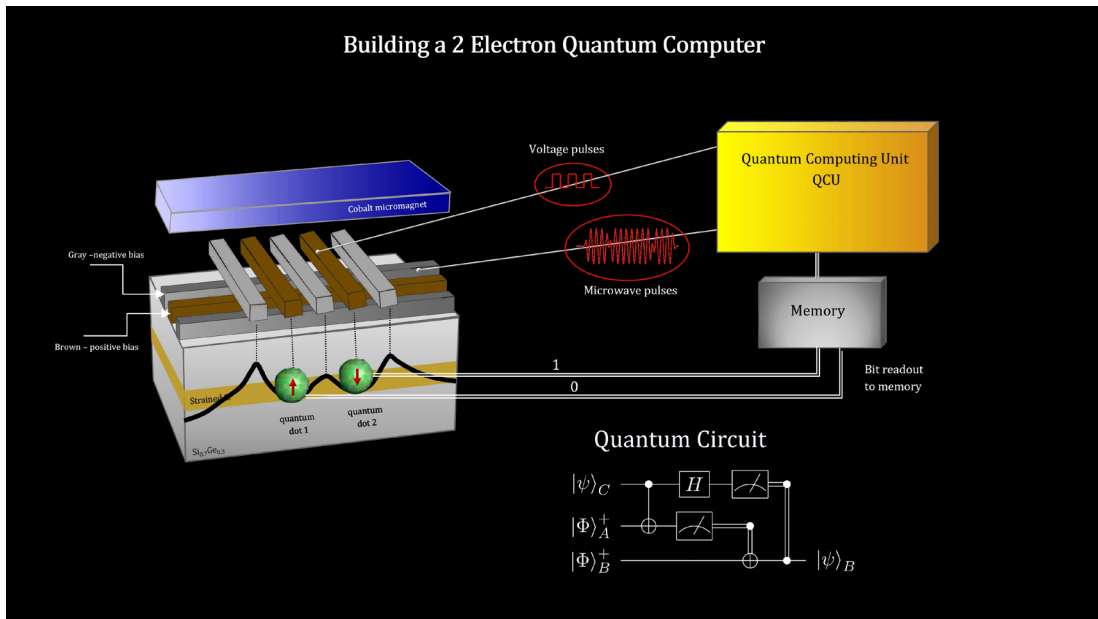



Quantum dot states are extremely fragile. The slightest vibration or change in temperature can cause them to tumble out of superposition causing errors – lots of errors.

That's why in order to best protect qubits from the outside world they are housed in supercooled fridges and vacuum chambers. This makes them very expensive compared to classic computers. Because of this, it is expected that quantum computers will only work on those problems that need a gigantic number of bits: jobs like factoring extremely large numbers.



Schrodinger pointed out that superposition and entanglement are the two primary characteristics of the quantum world. And whenever particles find themselves close together, they will become entangled - creating unobservable quantum states.

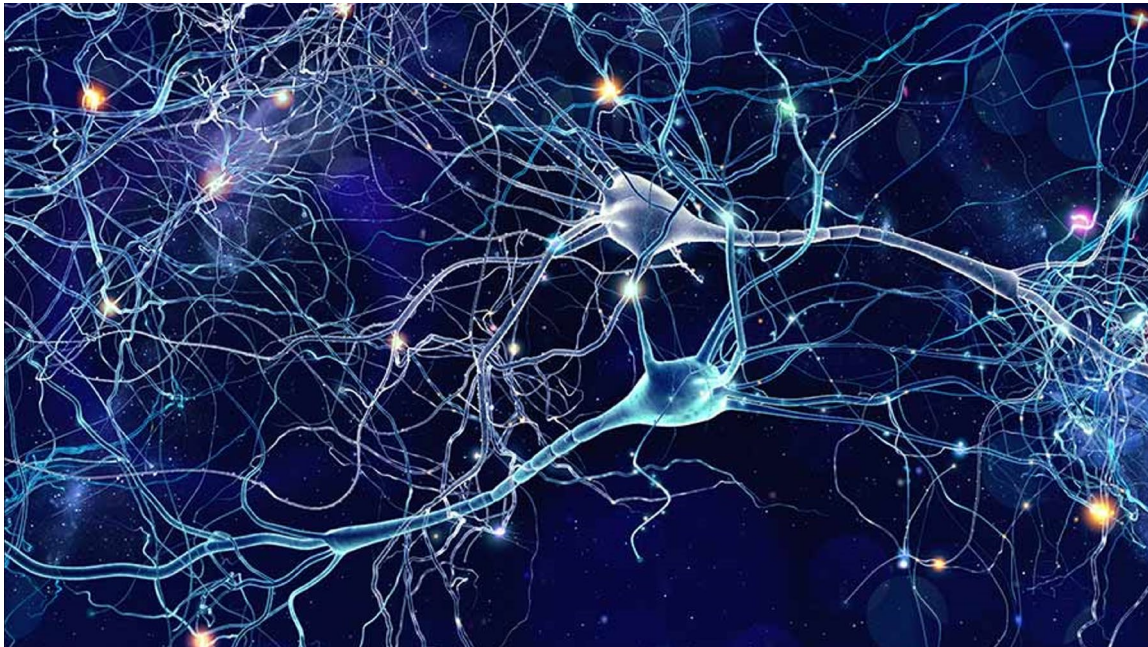



Music:

@00:00 Bach - Flute Concerto in B Flat, Adagio; conducted by Eckart Haupt; from the album Meditation: Classical Relaxation, 2010

@13:21 Puccini - La Bohème Act II- Musette Waltz; Sofia Philharmonic Orchestra; from the album 100 Must-Have Italian Opera Highlights, 2014

@26:50 Svendsen - Romance in G; Miklos Szenthelyi; from the album Meditation: Classical Relaxation, 2010

2^{100} is 1,267,650,600,228,229,401,496,703,205,376.
 In the US number naming system, it is one nonillion, 267 octillion, 650 septillion, 600 sextillion, 228 quintillion, 229 quadrillion, 401 trillion, 496 billion, 703 million, 205 thousand, 376.

Greek letters:
 - α β γ δ ε ζ η θ ι κ λ μ ν ξ ο π ρ σ τ υ φ χ ψ ω
 - Α Β Γ Δ Ε Ζ Η Θ Ι Κ Λ Μ Ν Ξ Ο Π Ρ Σ Τ Υ Φ Χ Ψ Ω

⇒ → ± ⊙ ∞ ↗ ∃ ∄ ∈ ∉ ∫ ∫ ∫ ≅ ≥ ≤ ≈ ≠ ≡ √ ∛ ~ ∝ ħ ÷ ∂ ⊥